

Highest quality for your skill



**DONATONI**  
HIGH INNOVATION STONE MACHINES



## QUADRIX DV 1000

**Centro di taglio a  
controllo numerico  
a 5 assi interpolati**  
CNC cutting center with  
5 interpolated axes



MADE IN ITALY



Ø 1000/1100 Z-STROKE CAD/CAM TOUCH



# QUADRIX DV 1000



Ogni macchina Donatoni nasce con un cervello tecnologico all'avanguardia. Cambiano le funzioni, le dimensioni e le capacità, ma il punto fermo è un sistema intelligente di gestione del lavoro. Semplice da usare, eccezionale nei risultati.

Each Donatoni machine comes with a cutting edge technological brain. Functions, dimensions and performances can change, but the basic assumption is an intelligent system of work management. Simple to use, outstanding results.







## Alta tecnologia di taglio al tuo servizio Advanced cutting technology at your service

QUADRIX DV 1000 TOP è un centro di taglio e sagomatura a controllo numerico a 5-6 assi interpolati con corsa asse Z di 800mm (opt. 900mm), testa porta disco rotante da  $-5^{\circ}$  a  $+365^{\circ}$  ed inclinabile da  $0^{\circ}$  a  $90^{\circ}$  per l'esecuzione di tagli ortogonali fino a 360mm (opt. 410mm), obliqui, circolari, ellittici, inclinati, sagomature rettilinee, concave, convesse, ad arco, ellittiche, scavi di masselli a sezione bidimensionale e tridimensionale.

La versione "Top" installa di serie l'elettromandrino controllato da inverter e può utilizzare utensili diamantati tipo: fresa a candela, mola da scavo, disco orizzontale.

QUADRIX DV 1000 TOP is a 5-6 interpolated axes CNC working centre with Z axis stroke of 800mm (opt. 900mm), rotating blade head swiveling from  $-5$  to  $+365$  degrees and tilting from 0 to 90 degrees, to perform orthogonal cuts up to 360mm (opt. 410mm), ideal machine for performing oblique, circular, elliptical cuts, two-dimensional and three-dimensional digging and carving of blocks.

The "Top" version can use diamond tools such as: milling wheels, drill cores, horizontal blade.

# QUADRIX DV 1000

## Particolari costruttivi / Structural details

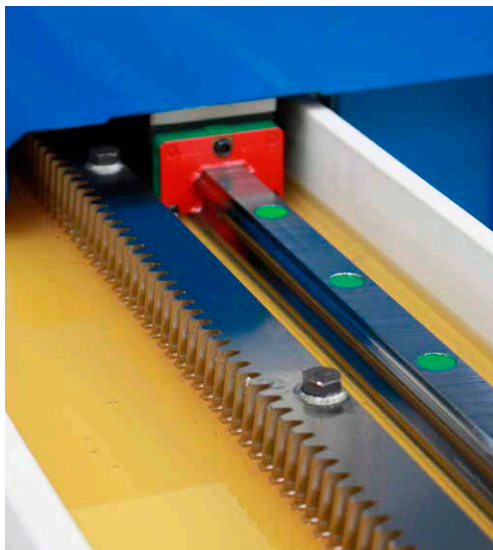

Scorrimento carrello porta disco (asse X e Y) su guide lineari a ricircolo di sfere in bagno d'olio.  
Blade carriage sliding (X and y axis) on recirculating ball linear guides in oil bath.



Movimentazione salita-discesa testa porta disco con vite a ricircolo di sfere, chiocciola e sistema di sicurezza ACS.

Head-carrying blade high-low drive with recirculating ball screw, lead nut and ACS safety system.

Scorrimento salita e discesa della testa (asse Z) su guide lineari a ricircolo di sfere.

Head up-down sliding (Z axis) on recirculating linear ball guides.

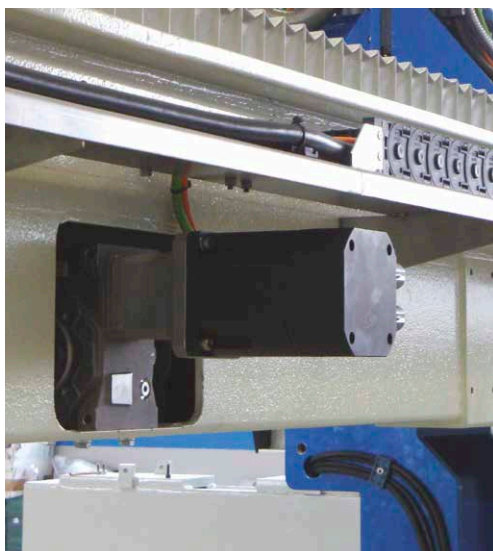

Per il movimento di tutti gli assi sono impiegati motori brushless e riduttori di alta precisione.  
Brushless motors and high precision gearboxes are used for all axes drive.



Rotazione testa (asse C) da -5° a 540°.

Inclinazione testa (asse A) da 0° a 90°.

Head rotation (C axis) from -5° to 540°.

Head inclination (A axis) from 0° to 90°.



## Optional

## Utensili / Tools

### RIEPILOGATIVO OPTIONAL / SUMMARY OF OPTIONALS

Banco basculante piano legno o gomma	Tilting table with wood or rubber surface
Banco fisso piano legno o gomma	Fixed table with wood or rubber surface
Rilevatore spessore lastra	Slab thickness detector
Presetting utensili e disco	Blade and tools presetting
Muri sostegno macchina in acciaio	Steel walls for machine support
Tornio CNC	CNC lathe
Testa portadisco mtc: elettromandrino ISO 50 con sgancio pneumatico	MTC blade-carrying head: ISO 50 electrospindle with pneumatic release
Testa portadisco atc: elettromandrino ISO 50 con cambio utensili automatico	ATC blade-carrying head: ISO 50 electrospindle with automatic tool changing
Magazzino cambio utensili automatico	Automatic tool changing magazine
Teleassistenza	Remote assistance
3D scanner	3D scanner
Fotocamera	Photocamera
Move system, ventose per spostamento pezzi	Move system, Multi section suction cups, for moving the pieces to be cut
Gruppo di taglio lower cut per taglio rinforzo o gocciolatoio	Lower cut unit for reinforcement cut or drip
Scan Cnc rilevatore di dime 2d	Scan CNC 2D templates detector
Parametrix	Parametrix
DM_TL Programma per levigatura con piatto porta frankfurt	DM_TL program for polishing equipped with frankfurt-carrying plate

### VENTOSE PER FISSAGGIO PEZZI VACUUM CUPS



### 3D SCANNER



### TORNIO CNC INTERPOLATO INTERPOLATED CNC LATHE



### UTENSILI DIAMANTATI UTILIZZABILI DIAMOND TOOLS USED



### CAMBIO UTENSILI AUTOMATICO AUTOMATIC TOOLS CHANGE



### PRESETTING DISCO E UTENSILI BLADE AND TOOLS PRESETTING





# QUADRIX DV 1000

Consolle comando macchina e software base / Machine control console and core operating system

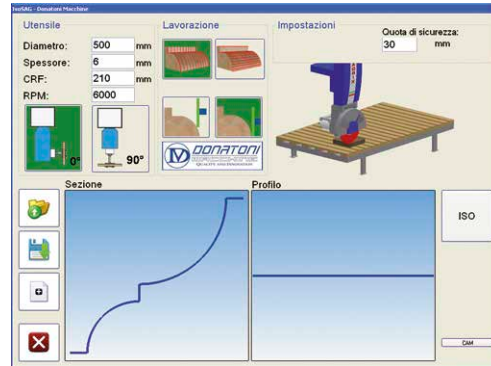

ISOSAG – MiniCAD software che permette di eseguire sagomature rettilinee o ad arco concavo e convesso, sia con disco in verticale che con disco orizzontale

ISOSAG – MiniCAD software to create shaping files to perform straight or concave and convex arc shapes with both vertical and horizontal blades

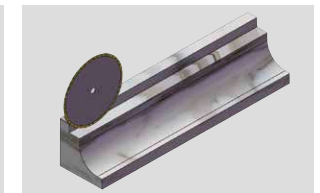
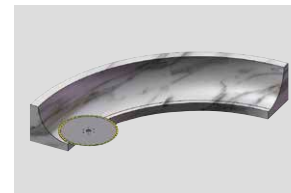

Interfaccia operatore con PC e video 15" touch-screen a colori  
Operator interface with PC and 15" color touch-screen monitor

Porta USB per trasferimento files  
USB port for file transfer

Comandi per la gestione manuale di tutti gli assi  
Controls for manual handling of all axes

**PROGRAMMI BASE INSTALLATI**  
BASIC PROGRAMS INSTALLED

FORATURA  
DRILLING



TAGLIO LASTRE COMBINATO  
COMBINED SLABS CUT



TAGLIO LASTRE COMBINATO OBLIQUO  
COMBINED OBLIQUE SLABS CUT



TAGLIO ELEMENTI CURVILINEI  
CURVILINEAR ELEMENTS CUT



TAGLIO INCLINATO  
INCLINED CUT

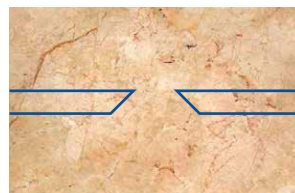

SCAVO SEMPLICE  
SIMPLE DIGGING



TAGLIO POLIGONI  
POLYGONAL CUT



TAGLIO CERCHIO ED ELLISSE  
CIRCULAR AND ELLIPTICAL CUT



TAGLIO PIANO CUCINA  
KITCHEN TOP CUT





## Software: EasyStone CAD/CAM

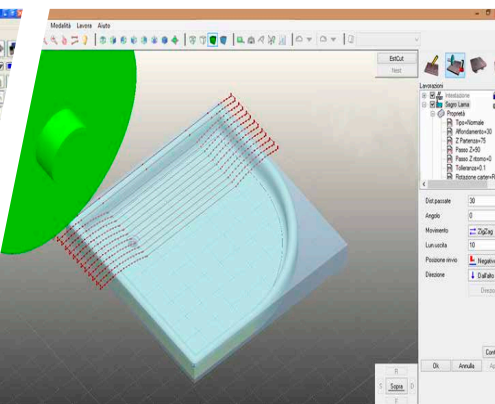
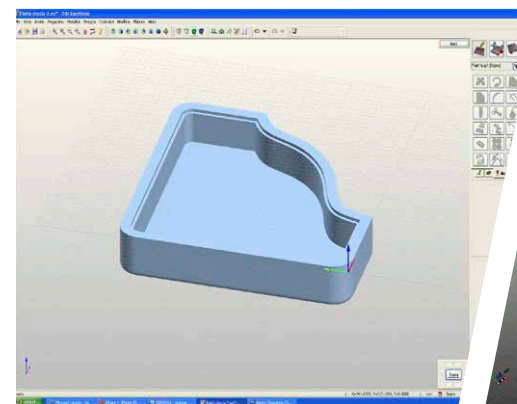
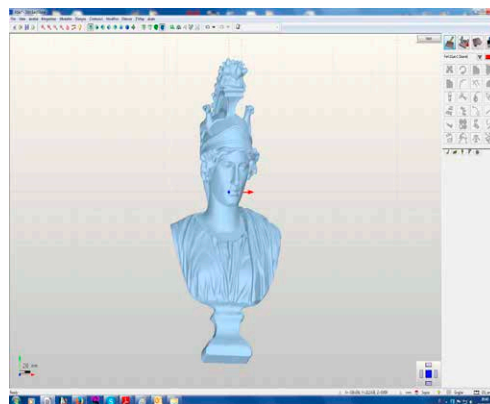
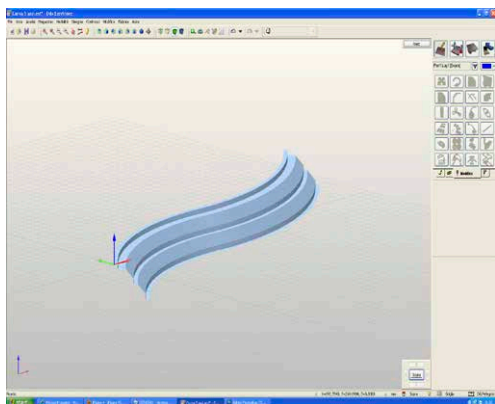

**Un software CAD/CAM potente, semplice ed intuitivo. Nella fase di progettazione permette di disegnare liberamente elementi geometrici e superfici: piani cucina, top bagno, colonne e sagome**

Il software consente di importare file 2D e 3D nei formati DXF, IGES, STL, PNT, STEP e RHINO e di definire superfici e sagome attraverso la scansione laser. Si possono impostare molteplici lavorazioni: sgrossature, forature, profilature, svuotamenti e lucidature, sono eseguite ottimizzando il processo di esecuzione.

La disposizione e la realizzazione dei pezzi è effettuata in automatico gestendo gli utensili ed il portautensili, con controllo delle interferenze delle lavorazioni.

EasyStone gestisce il tornio interpolato.

**A CAD / CAM powerful software, simple and intuitive. In the design phase it allows to draw freely geometric elements and surfaces: kitchen countertops, vanity tops, columns and silhouettes.**

The software allows import of 2D and 3D file formats DXF, IGES, STL, PNT, STEP and RHINO and to define shapes and surfaces by laser scanning. You can set multiple processes: roughing, drilling, profiling, emptying and polishing, are performed by optimizing the execution process.

The arrangement and production of pieces is automatically performed by managing tools and tool holders, with interference checking.

EasyStone manages the interpolated lathe.

# QUADRIX DV 1000

Fotolastra / Photoslab

Software: Parametrix

Move System (patent pending)

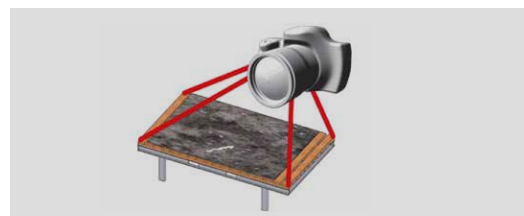
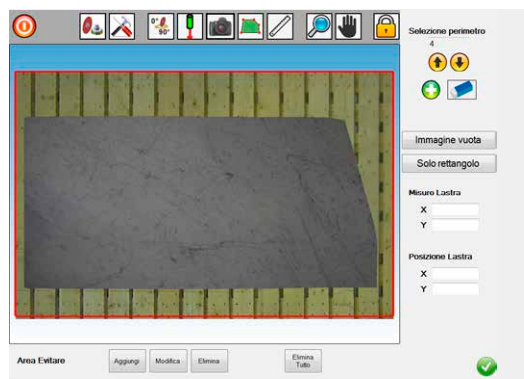

## FOTOCAMERA | CAMERA

Photoslab, per mezzo di una fotocamera, rileva automaticamente le misure della lastra da tagliare. Il sistema permette di velocizzare il posizionamento dei pezzi, evitando eventuali difetti oppure permettendo di eseguire tagli seguendo le venature del materiale.

Photoslab, per mezzo di una fotocamera, rileva automaticamente le misure della lastra da tagliare. Il sistema permette di velocizzare il posizionamento dei pezzi, evitando eventuali difetti oppure permettendo di eseguire tagli seguendo le venature del materiale.

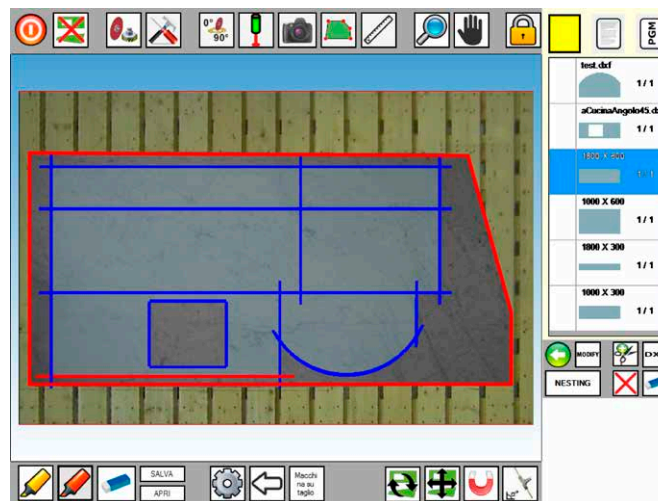

## Software per la gestione di figure parametrizzate: PARAMETRIX

Un software sviluppato dalla Donatoni Macchine pensato per ottimizzare la gestione dei tagli multipli su lastra. Parametrix, in base alla superficie disponibile, consente di impostare in automatico la disposizione dei pezzi e la sequenza dei tagli, ottimizzando i tempi e riducendo gli scarti di materiale.

## Software for the management of cuts: PARAMETRIX

A software developed by Donatoni Macchine; designed to optimize the management of multiple cuts on the slab. Parametrix, according to the area available, allows you to automatically set the pieces position and the sequence of cuts, optimizing time and reducing material waste.

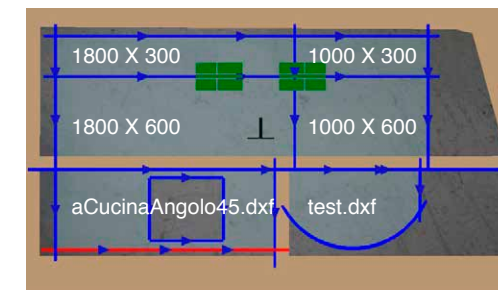

## SISTEMA VENTOSE

Move System è un innovativo sistema di ventose per la movimentazione dei pezzi tagliati. Il suo utilizzo riduce i tempi morti, aumenta la produttività limitando al minimo il materiale di scarto.

## MOVE SYSTEM

Move System is an innovative system of vacuum cups for handling cut to sizes pieces. Its use reduces downtime and increases productivity while minimizing material waste.





## Lavori / Works

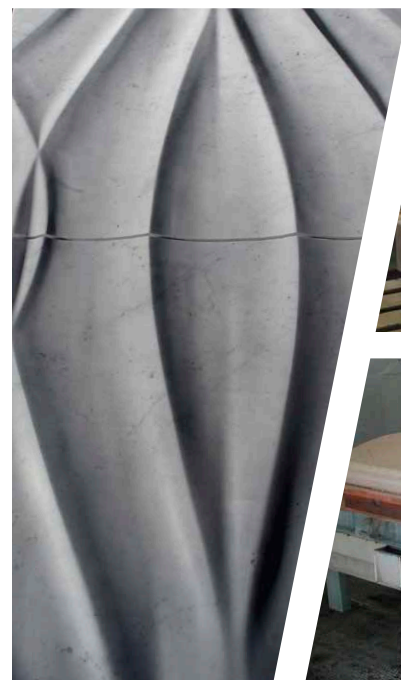

# QUADRIX DV 1000

Elevata produttività e precisione / High productivity and accuracy

QUADRIX DV 1000 TOP permette di ottenere prodotti dalle dimensioni estremamente precise ed una produzione elevata grazie agli scorrimenti degli assi X e Y che avvengono su guide lineari a ricircolo di sfere e cremagliere a denti temperati e rettificati, entrambi con lubrificazione in bagno d'olio. Il moto è generato da motori brushless accoppiati a riduttori ad alta precisione.

QUADRIX DV 1000 TOP allows to obtain accurately shaped products and high productivity thanks to the X and Y axes, that slide on linear roller guides with hardened steel tooth, both with oil bath lubrication. The motion is generated by brushless engines paired with high precision adaptors.

ESEMPIO INGOMBRI PROLUNGHE  
EXAMPLE OF EXTENSIONS DIMENSIONS

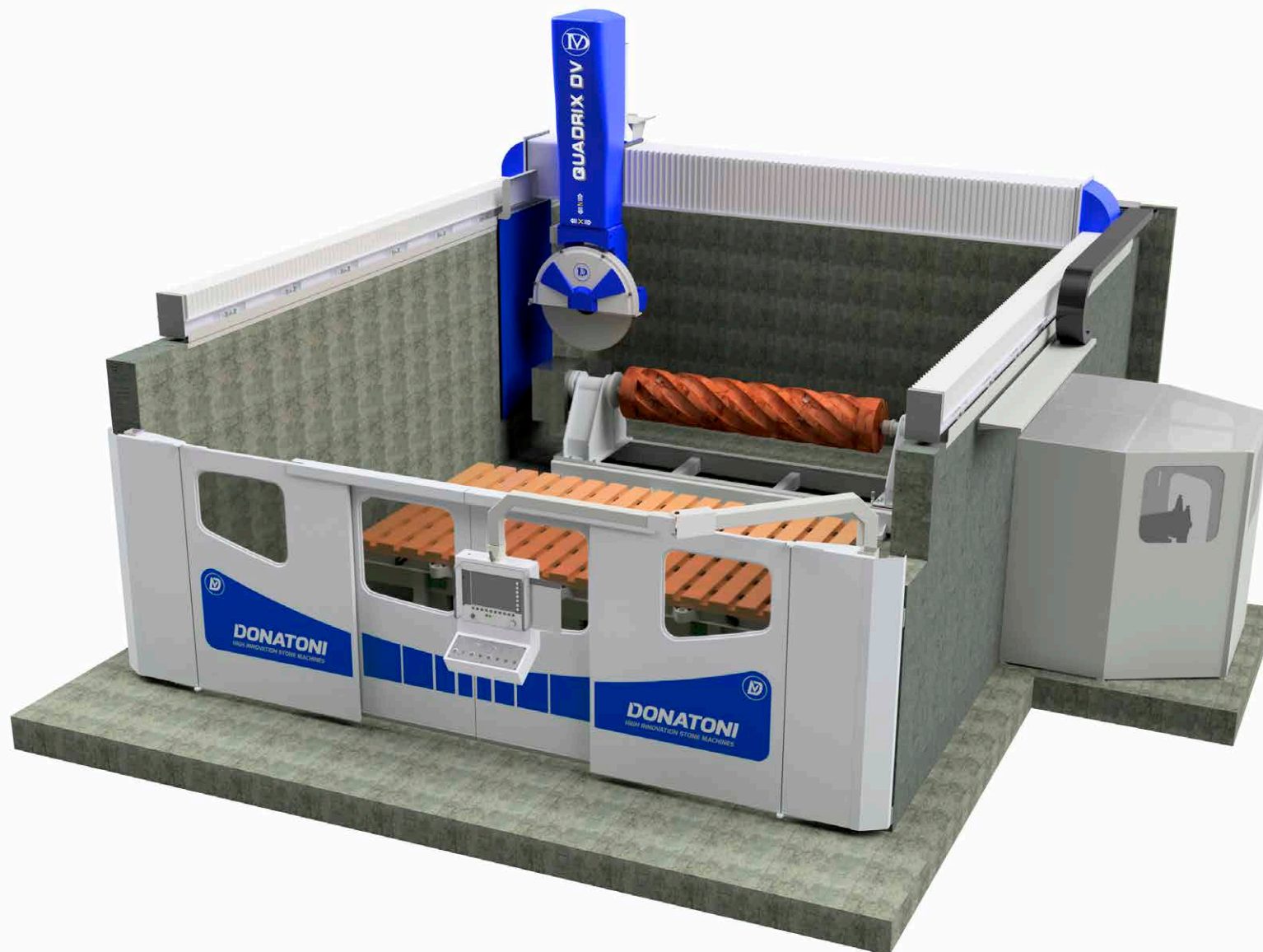
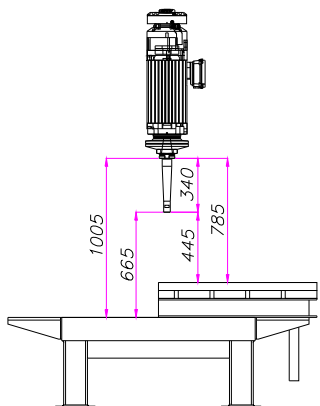





## Dimensione / Dimensions

## Caratteristiche Tecniche / Technical Features

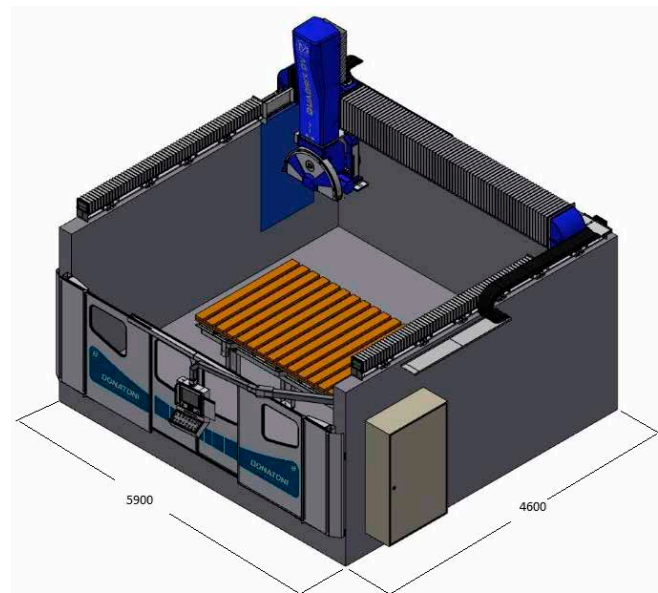
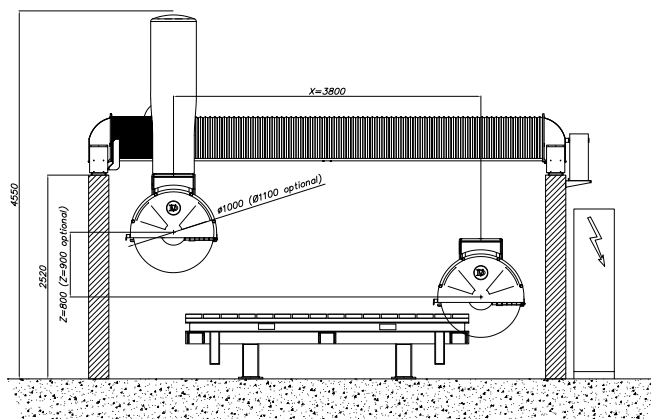

Numero massimo assi interpolati Max number of interpolated axes	N°	5 / 6	Potenza motore elettromandrino Electro spindle motor power	kW Hp	31 / 56 41.5 / 56
Corsa carrello asse X * Carriage stroke ( axis X ) *	mm in	3800 150	Rotazione disco con inverter Disc rotation with inverter	giri/min Rpm	0 / 6000
Corsa ponte asse Y * Bridge stroke ( axis Y ) *	mm in	2700 106	Attacco utensile cono Tool connection	ISO ISO	50
Corsa salita / discesa testa asse Z Vertical stroke of the head ( axis Z )	mm in	800 / 900 (opt.) 32 / 36 (opt.)	Velocità massima assi X-Y Max speed X-Y axes	m/min ft/min	45 148
Rotazione testa porta disco asse C Disc head rotation (axis C)	gradi degrees	-5° / +540°	Velocità massima testa asse Z Max speed axis Z	m/min ft/min	13 43
Inclinazione testa porta disco asse A Blade-carrying head tilting (axis A)	gradi degrees	0° / 90°	Consumo acqua Water consumption	l/min gal/min	50 14
Dimensioni banco di lavoro * Working table dimensions *	mm in	2000x3500 79x138	Consumo aria Air consumption	l/min gal/min	10 3
Diametro minimo del disco Minimum disc diameter	mm in	500 20	Tensione standard Standard voltage	Volt/Hz	400 / 50
Diametro massimo del disco Maximum disc diameter	mm in	1000 / 1100 (opt.) 40 / 43 (opt.)	Peso complessivo della macchina Approx. total weight of the machine	kg	7000
Profondità massima di taglio Maximum cutting depth	mm in	360 / 410 (opt.) 14 / 16 (opt.)			

\* Altre misure su richiesta  
\* different dimensions under request

I dati non sono impegnativi e la ditta costruttrice si riserva la facoltà di modificarli senza preavviso per migliorare le prestazioni del prodotto  
Technical data are not binding and the firm has the right to modify them without notice due continuous improvement of the product



Member of:



CONFINDUSTRIA MARMOMACCHINE  
ASSOMARMOMACCHINE

[www.donatonimacchine.eu](http://www.donatonimacchine.eu)

### Donatoni Macchine Srl

Via Napoleone 14, 37015 Domegliara / Verona / Italy

Tel. +39 045 6862548

Fax +39 045 688 43 47

[info@donatonimacchine.eu](mailto:info@donatonimacchine.eu)

[www.donatonimacchine.eu](http://www.donatonimacchine.eu)



## Un'azienda al servizio del cliente! / Customer service is our business

L'impegno verso i nostri clienti non si esaurisce con la consegna della macchina, ma continua, offrendo un supporto ed una assistenza postvendita di qualità assoluta. La possibilità di implementare su tutte le nostre macchine il servizio di 'Tele Assistenza', permette al nostro staff tecnico di poter accedere virtualmente sulla macchina del cliente ed eseguire controlli, verifiche ed aggiornamenti, come se si trovasse lì di persona. Il nostro personale, altamente qualificato ed appositamente formato sul concetto di Customer Oriented, è sempre a disposizione del cliente.

OUR commitment to our customers does not end with the delivery of the machine. Our commitment continues by offering support and the highest level of after-sales service. Through our "Remote Assistance" module, our technical staff has the ability to have virtual access on the customer's machine to perform checks, verifications, and updates as if they are there in person. Our staff, highly qualified and trained on the concept of Customer Service, is always available at the customer's disposal.

## Una storia di successo / A success story

Donatoni Macchine, fondata da Donatoni Vittorio nel 1959, da oltre 50 anni ha la propria sede a Domegliara in provincia di Verona, una tra le principali zone di trasformazione e lavorazione del marmo e del granito. La lunga esperienza maturata negli anni in varie attività del settore lapideo rappresenta una garanzia di serietà e competenza indispensabili per proporre idee e soluzioni innovative e concrete nella realizzazione delle macchine per la lavorazione del marmo e del granito. L'organizzazione aziendale composta da personale tecnico e commerciale altamente qualificato completano il profilo di una realtà volta a soddisfare il cliente in ogni dettaglio.

Donatoni Macchine, founded by Vittorio Donatoni in 1959, for over 50 years has been headquartered in Domegliara, in the province of Verona, one of the main marble and granite processing areas. Years of experience gained in the stones business are behind the reputation and the expertise that permit Donatoni Macchine to offer innovative and practical ideas and solutions in design of marble and granite processing machines. Company organization, consisting of highly qualified technical and sales staff, completes the picture of a company that aims at fulfilling all customer's requirements.